

## BILL OF SALE AND RELEASE AGREEMENT

KNOW ALL MEN BY THESE PRESENTS that in satisfaction of the Site Agreement dated September 2, 1997, as amended by Amendment to Lease dated August 26, 2003, and terminated as of the effective date hereof (hereinafter the "Lease"), United States Cellular Operating Company of Chicago, LLC, a Delaware limited liability company, successor in interest to PrimeCo Personal Communications, L.P., d/b/a U.S. Cellular, with an address at 8410 West Bryn Mawr, Suite 700, Chicago, Illinois 60631 ("Seller"), does hereby sell, transfer and convey unto, Village of Palos Park, an Illinois municipal corporation, successor in interest to Shadow Ridge Signature Development, LLC, successor in interest to St. Coletta's of Illinois, with an address at 8999 W. 123<sup>rd</sup> Street, Palos Park, IL 60464 ("Buyer"), for and in return of One and 00/100 Dollar (\$1.00) and other good and valuable consideration, the receipt and sufficiency of which is hereby acknowledged, the following item or items, more particularly described as follows:

Ice Bridge, Ice Bridge Posts, and Ice Bridge Posts Foundation all located at 12150 Wolf Road, in Palos Park, IL 60464, along with related and ancillary improvements, as shown in part in Exhibit A, and all AS IS, WHERE IS, with NO WARRANTIES OF ANY KIND (Hereinafter the equipment and all related and ancillary improvements is referred to as the "Equipment")

1. **Condition of Equipment; Disclaimer of Warranties and Release.** Buyer hereby acknowledges that it, or its employee(s), agent(s), or contractor(s), has the expertise necessary to inspect the Equipment, and that it or its employee(s), agent(s), or contractor(s), has inspected the Equipment in its current condition as of the effective date of this Bill of Sale. The Equipment is transferred to Buyer AS IS, WHERE IS, AND WITHOUT WARRANTIES, EXPRESS OR IMPLIED, OF ANY KIND, INCLUDING THE WARRANTIES OF MERCHANTABILITY AND FITNESS FOR A PARTICULAR PURPOSE. Except for those representations specifically enumerated in paragraph 2 below, Buyer, for itself, its successor, agents, and assigns, hereby releases and forever discharges Seller, its successors, assigns, affiliates, agents, employees and legal representatives from any and all claims, losses, and demands or liability of every kind, whether known or unknown, which Buyer has, or may have, arising out any use or ownership of the Equipment either now or in the future, and Buyer assumes all risk related or arising from the Equipment. This Release is binding upon Buyer, its successors, agents, employees, assigns and legal representatives, and inures to the benefit of Seller and its successors, assigns, affiliates, agents, employees and legal representatives.
2. **Seller's Representations.** Seller represents only that as of the date hereof, Seller is the owner of the Equipment, free and clear of any lien, security interest or encumbrance, and that no financing statement covering said Equipment or any proceeds thereof is on file in any public office.
3. **Waiver of Lease Obligations.** Buyer, as Landlord, and Seller were parties to the Lease, which Seller terminates as of the date hereof if not previously terminated. Buyer acknowledges that the Lease contained an obligation for Seller remove its personal property and fixtures, and that instead Seller has agree to transfer such personal property and fixtures to Buyer by way of this Bill of Sale, and therefore Buyer agrees to waive any and all

obligations remaining under the Lease for remediation of the Premises, and accepts the Premises, and personal property and fixtures of Tenant pursuant hereto. Except for those representations specifically enumerated in paragraph 2 above, Buyer, for itself, its successor, agents, and assigns, hereby releases and forever discharges Seller, its successors, assigns, affiliates, agents, employees and legal representatives from any and all claims and demands, whether known or unknown, which Buyer has, or may have, arising out of the Lease either now or in the future.

4. **Acknowledgement of Obligations, Authority, Expertise.** Buyer acknowledges that taking ownership of the Equipment pursuant hereto may make it responsible for certain obligations and regulations in regard to registering the Equipment or continuing to register the Equipment with the Federal Aviation Authority ("FAA") and the Federal Communication Commission ("FCC") and Buyer will be responsible for compliance with any and all laws, rules, regulation related to the Equipment whether municipal, state, federal, or otherwise required. Buyer represents that it has the appropriate authority to enter into this Bill of Sale and appropriate expertise and technological knowledge to take ownership of the Equipment.

(End of Agreement - Signature Page Follows)

IN WITNESS WHEREOF, SELLER AND BUYER have caused this Bill of Sale to be duly executed and effective as of the date of full execution by both parties (the "Effective Date").

SELLER:

United States Cellular Operating  
Company of Chicago, LLC,  
a Delaware limited liability company

By: Erin M Wolf  
Printed: ERIN M WOLFF  
Title: SR MER CSEHS  
Date: 1/2/15

BUYER

Village of Palos Park,  
an Illinois municipal corporation

By: RB Boel  
Printed: RB BOETHM  
Its: VILLAGE MANAGER  
Date: 12/19/14

**EXHIBIT A**

**Illustrative Depictions of Transferred Equipment**





837.230.79.012  
**CODY/BRAIN & ASSOCIATES, INC.**  
 REGISTERED PROFESSIONAL ENGINEERS - ILLINOIS  
 2015-01-01-2017-12-31

OTHER:



**PRIMECO**  
 PRIME COMMUNICATIONS  
 ONE PIERCE PLACE - SUITE 1100  
 TASCALA ILLINOIS 60143  
 630-776-1600 FAX: 630-773-8988

**PROJECT TITLE:**  
 WATER TOWER MOUNTED ANTENNA  
 SITE 8810-1  
 ST. COLBERT'S  
 12850 & WOLF ROAD  
 COOK COUNTY, PALDS PARK, IL.

**APPROVALS:**

DESIGNED	_____
LANDSCAPED	_____
LANDING	_____
R.F.	_____
ZONING	_____
CONSTRUCTION	_____
BBB	_____

**DRAWING PRINTING/REVISION DATES**

REV	PRINTD	ITEM

**DATE:** 07-15-17

**JOB NUMBER:** 17054

**DRAWN BY:** 644

**SHEET TITLE:** SECTIONS

**SHEET NO.:** A-4  
 of 06

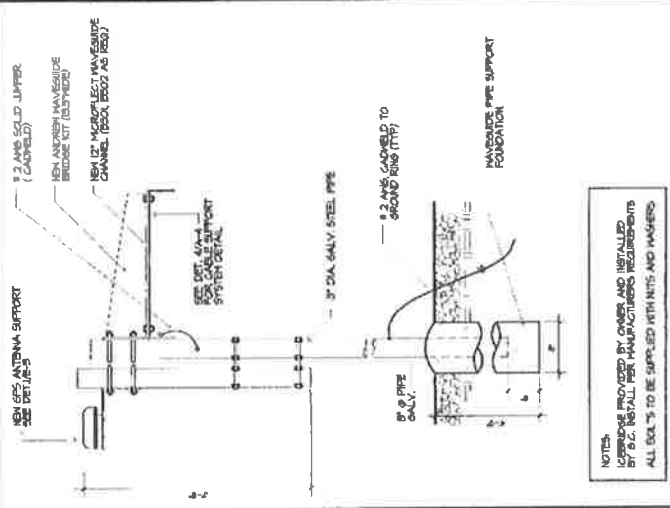

**NOTES:**  
 1. IMPROVE PROVIDED BY OWNER AND INSTALLED BY GC. INSTALL PER MANUFACTURER REQUIREMENTS ALL BOLTS TO BE SUPPLIED WITH NUTS AND WASHERS

2  
 A-4

**SECTION**  
 SCALE: NOT TO SCALE

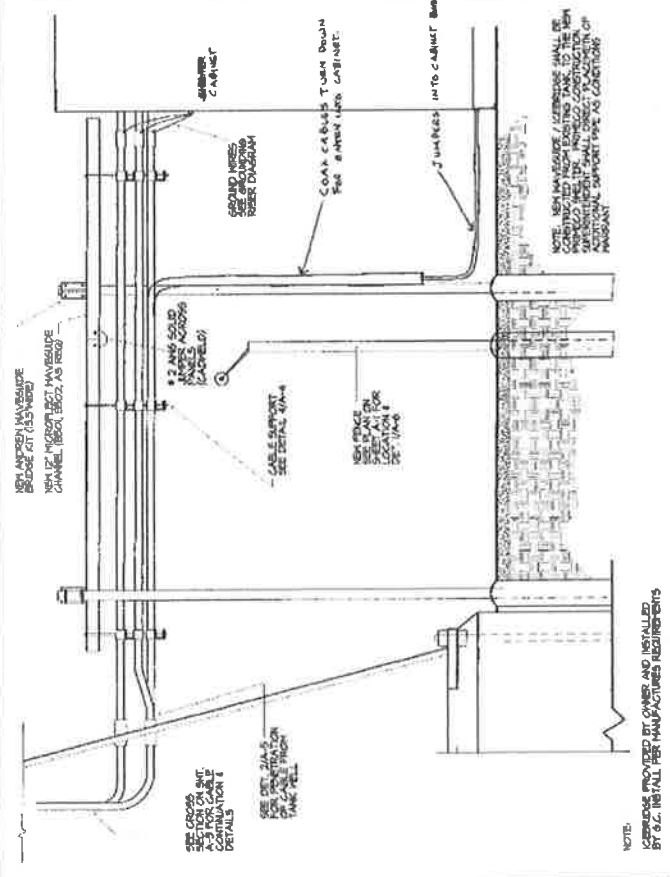

**NOTE:**  
 IMPROVE PROVIDED BY OWNER AND INSTALLED BY GC. INSTALL PER MANUFACTURER REQUIREMENTS

1  
 A-4

**SECTION**  
 SCALE: NOT TO SCALE

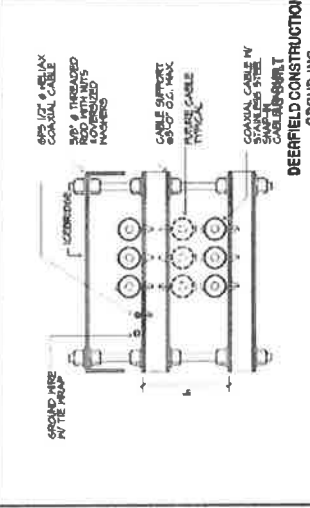

**NOTES:**  
 1. IMPROVE PROVIDED BY OWNER AND INSTALLED BY GC. INSTALL PER MANUFACTURER REQUIREMENTS

4  
 A-4

**SECTION**  
 SCALE: 1/2\"/>

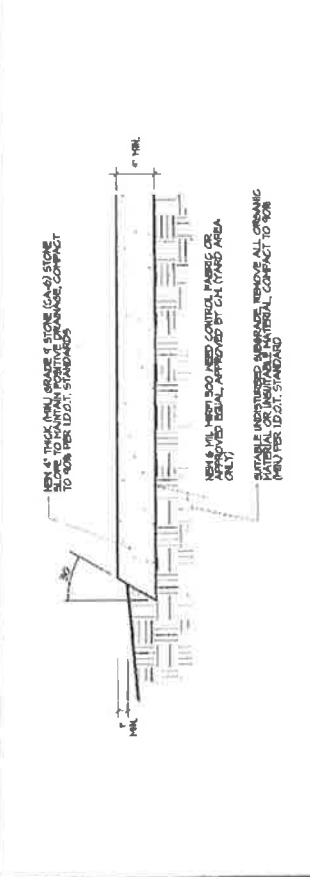

**NOTE:**  
 NEW CONTROL FABRIC SHALL BE USED UNDER ALL AREAS OF THE YARD, INCLUDING UNDER THE WETTER.

3  
 A-4

**YARD/DRIVEWAY PAVEMENT**  
 SCALE: 1/2\"/>